

Wet Multi Disc Brake 6.5"

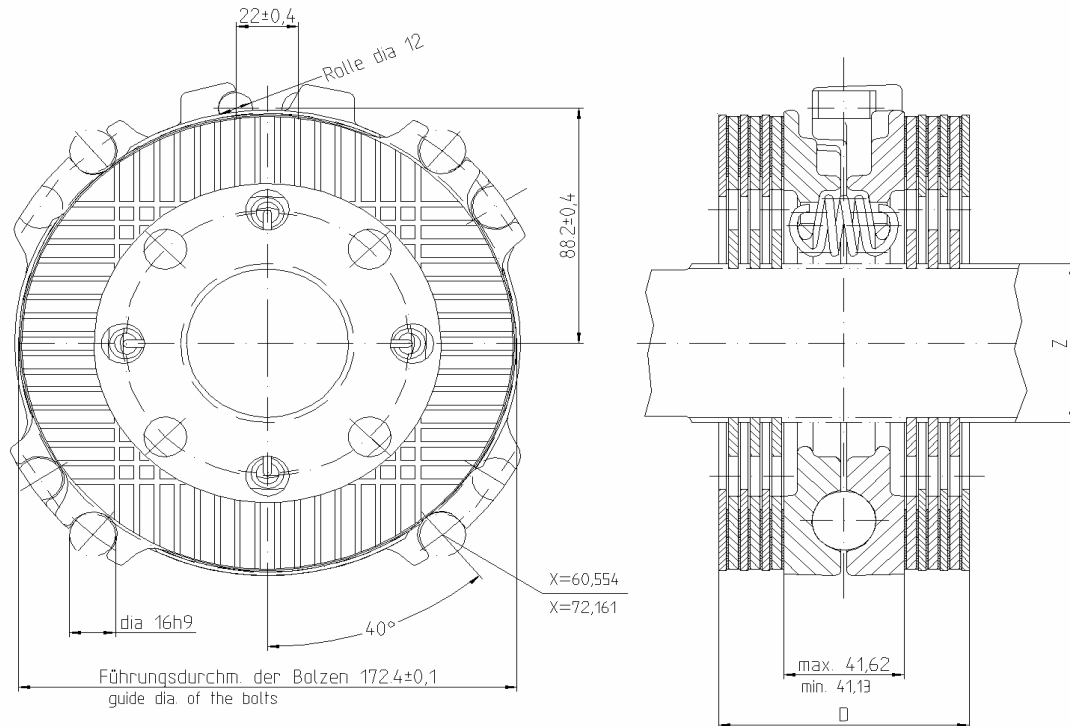

**special types
on request**

Art. no.	max. brake-torque [Nm]	lining-quality	lining type	groove pattern	ramp angle	Monoservo/ Multiservo	number of lining discs	number of intermediate discs	max. thickness "D"	Spline (Z)
12921	3500	HO 101.3	Papier	2-fach-parallel	34°	Multi	6	6	86.95	N60x2x28x9H DIN 5480
12932	2335	HO 101.3	Papier	2-fach-parallel	34°	Multi	4	3	69.185	N60x2x28x9H DIN 5480
13021	3500	D294.1	Sinter	Sunburst	28	Multi	6	6	86.95	A 40x36 DIN 5482
13046	3500	HO 101.3	Papier	2-fach-parallel	32	Multi	6	6	95.44	N60x2x28x9H DIN 5480
13105	2900	HDT 303	Graphit	Waffelnut	34	Multi	5	4	76.74	N60x2x28x9H DIN 5480
13232	3500	HDT 303	Graphit	Waffelnut	34	Multi	6	6	86.95	N60x2x28x9H DIN 5480
13244	2335	HDT 303	Graphit	Waffelnut	34	Mono	4	3	69.185	N60x2x28x9H DIN 5480
13442	3500	D294.1	Sinter	Sunburst	28	Multi	6	6	86.95	A 50x45 DIN 5482
13488	2335	HDT 303	Graphit	Waffelnut	34	Multi	4	3	69.19	N60x2x28x9H DIN 5480
13569	2500	HS 48	Sinter	Sunburst	38	Multi	6	4	87.3	A 45x41 DIN 5482
13746	2335	HDT 303	Graphit	Waffelnut	34	Multi	4	2	66.3	N60x2x28x9H DIN 5480
13747	2919	HDT 303	Graphit	Waffelnut	34	Multi	6	4	81.64	N60x2x28x9H DIN 5480
13773	1900	HDT 303	Graphit	Waffelnut	34	Mono	5	5	79.4	N60x2x28x9H DIN 5480
14334	1150	HDT 303	Graphit	Waffelnut	34	Mono	3	1	59.43	N60x2x28x9H DIN 5480
100675	2919	HDT 303	Graphit	Waffelnut	34	Multi	5	5	79.4	A 45x41 DIN 5482

Wet Multi Disc Brake 8.75"

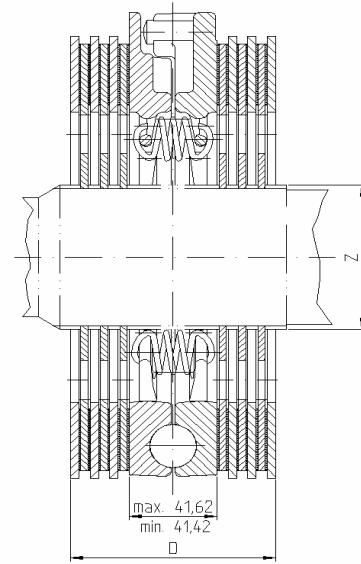
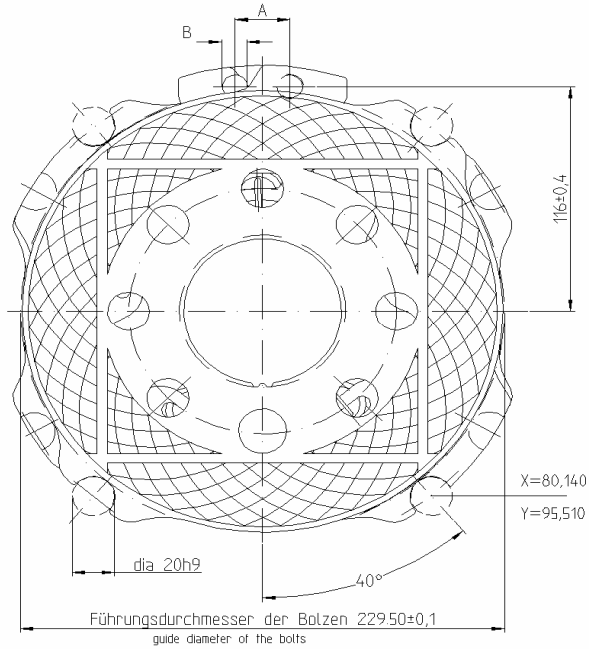

special types on request

Art. no.	max. brake-torque [Nm]	lining-quality	lining type	groove pattern	ramp angle	Monoservo/ Multiservo	number of lining discs	number of intermediate discs	D	A	B	Spline (Z)
12995	7900	HO 101.3	Papier	3-fach-parallel	34	Multi	6	6	87.04	26	12	N 75x2x30x36-9H DIN 5480
13089	4700	HS 48	Sinter	Sunburst	30	Multi	6	6	87.04	26	12	N 75x2x30x36-9H DIN 5480
13133	7900	D294/1	Sinter	Spiral + Tangential	30	Multi	6	6	87.04	26	12	N 75x2x30x36-9H DIN 5480
13255	3000	HDT 303	Graphit	Waffelnut	35	Multi	5	5	79.47	26	12	N 75x2x30x36-9H DIN 5480
13285	3150	HS 48	Sinter	Sunburst	30	Multi	4	4	71.9	26	12	A 100x94 DIN 5482
13292	6200	HS 48	Sinter	Sunburst	30	Multi	8	8	102.18	26	12	A 100x94 DIN 5482
13425	7800	HDT 303	Graphit	Waffelnut	30	Multi	6	6	87.04	26	12	A 50x45 DIN 5482
13460	7800	HDT 303	Graphit	Waffelnut	30	Multi	6	6	87.04	26	12	N 75x2x30x36-9H DIN 5480
13553	3600	HO 101.3	Papier	Waffelnut	28	Mono	5	4	74.8	26	16	N 60x2x28-9H DIN 5480
13554		HO 101.3	Papier	Waffelnut	28	Mono	6	5	81.97	26	16	N 60x2x28-9H DIN 5480
13687		D304	Sinter	Sunburst	30	Mono	6	6	87.04	26	12	N 75x2x30x36-9H DIN 5480
13724	5450	HS 48	Sinter	Sunburst	30	Multi	7	7	94.61	26	12	N 75x2x30x36-9H DIN 5480
13816	4300	HO 112.5	Papier	Waffelnut	28	Mono	4	2	67.56	26	16	N 72x60 DIN 5480
13830	7800	HDT 303	Graphit	Waffelnut	30	Multi	6	6	87.04	26	12	N 60x2x28-9H DIN 5480
13853	3600	HO 101.5	Papier	Waffelnut	28	Mono	5	4	74.55	26	16	N 60x2x28-9H DIN 5480
14280		HDT 303	Graphit	Waffelnut	30	Multi	5	5	79.47	26	12	N 75x2x30x36-9H DIN 5480
14319	4300	HO 112.5	Papier	Waffelnut	28	Mono	4	2	67.56	22	12	N 72x60 DIN 5480
101091	2150	HO 112.5	Papier	Waffelnut	28	Mono	2	0	50.55	22	12	N 72x60 DIN 5480
101092	4300	HO 112.5	Papier	Waffelnut	28	Mono	4	2	67.56	22	12	N 72x60 DIN 5480
100361		HS 48	Sinter	Sunburst	30	Multi	6	6	95.44	26	12	N 75x2x30x36-9H DIN 5480

